

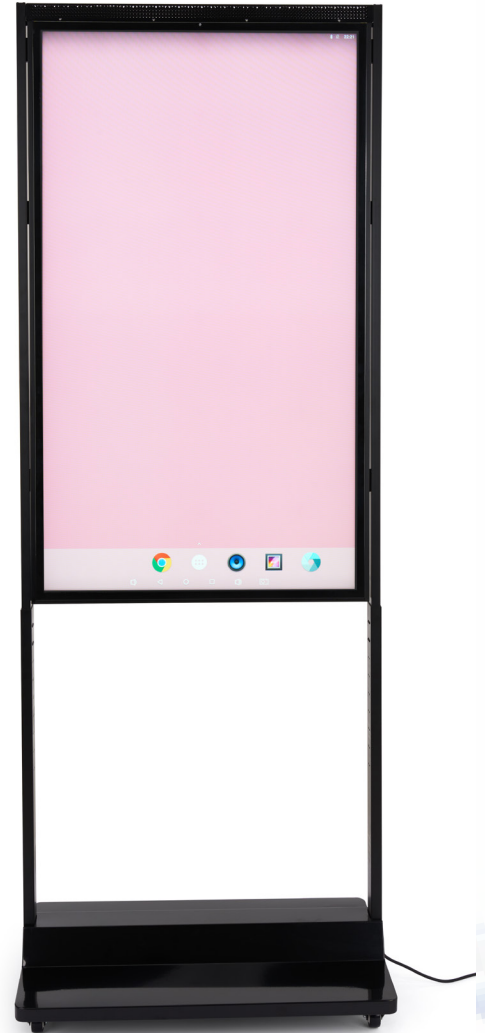

DISPLAYS2GO



DISPLAYS2GO DIGITAL 55" High Brightness Dual Sided Digital Window Signage USER MANUAL

SKUs: DGHBDWS55

Description: 55" High Brightness Dual Sided Digital Window Signage

NOTE: Before using the product, please read the instructions carefully.

Do not attempt to disassemble this product. If the product does not work properly, please call our Customer Service Department at 1-844-221-3393.

TABLE OF CONTENTS

Safety Warnings and Precautions	3
Features	6
Assembly and Connection	6
• Important: Assembly Information	6
• Parts List.....	7
• Interfaces	8
• Floor Standing Assembly	8
• Ceiling Mounted Assembly	11
Remote Control	15
Description of Basic Operation	16
• Power On/Standby.....	16
• About Launch Desktop.....	16
• Description of Wallpaper Switch	16
• File Manager	17
• Local Settings.....	17
• Description of Settings Interface	18
DiViEx APP Introduction	19
• How to Upload Media Files.....	19
• Settings.....	19
• Edit Picture(s)	20
• Music.....	21
• Factory Reset	21
• Screen Rotation	21
• Choose System Language.....	22
• Technical Specifications	23
Cleaning and Maintenance	24
Recycling and Disposal Regulations	24
Troubleshooting	25

NOTE: Professional installation is recommended when choosing to install the digital signage by the “Ceiling Mount Assembly”.



SAFETY WARNINGS AND PRECAUTIONS

Thank you for buying this product from Displays2go. We have taken personal safety into account in product design and carried out rigorous tests in the factory. However, improper installation and use can lead to electric shock and fire. To ensure safe use, maximize the performance of the product, and prolong the service life of the product, please read and follow all instructions carefully before using the product.

Keep instructions for future reference.

We strongly recommend using standard adapters and portable power supplies, or adapters with internal circuit breakers to prevent bad power supplies from damaging the device.

WARNINGS:

	Warning: May cause personal injury or death
	The operation is prohibited
	Caution: May cause damage or property loss

If any of the following occurs:

- Voltage is unstable
- The device has an abnormal sound or smell
- The DC power cable is damaged
- Equipment falls, knocks, impacts, and/or otherwise damages unit
- Any liquid or foreign matter falling into the shell

Immediately disconnect the power supply of the device, unplug from power socket, and contact Displays2go for assistance.

If coal gas or other flammable gas leaks, do not pull out the plug of the equipment or other electrical appliances; instead, turn off the gas valve immediately, and open the doors and windows quickly.

WARNINGS

- Do not use power supplies with DC or AC output other than 12V 3A or mobile power supplies.
- Disconnect the power supply before connecting or disconnecting any cable.
- Do not place the device in an unstable position to avoid damage or fire.
- Do not place the device in the following positions:
 - Exposure to direct sunlight, humidity, extreme temperature, or excessive dust
 - Flammable and explosive environment
 - Flammable and corrosive gas environment
- Do not use damaged or improper power sockets and ensure that the plug is in normal contact with the socket.
- Do not allow dust or metal deposits to adhere to plugs and sockets.
- Do not damage the power cord:
 - Do not modify the power cable.
 - Do not place heavy objects on the power cord.
 - Keep the power cable away from heat source.
 - Do not unplug the power cord.
- Do not connect multiple plugs at the same time. Otherwise, excessive power consumption may cause fire.
- Do not use an open flame (such as a lit candle) near the device. Electric shock or fire may occur.
- Do not put sharp objects, metals, or liquids into the contact signal terminals to avoid short circuit, product damage, or electric shock.
- The internal opening of the chassis is designed for ventilation and heat dissipation to ensure the reliable operation of the components in the chassis for a long time and to prevent overheating. Do not block the opening when placing the unit.
- Do not touch the plug with wet fingers. Electric shock may occur.
- Do not use equipment in stormy weather, especially when there is lightning. To avoid lightning strikes, disconnect the power supply and antenna plug.
- Do not use the equipment outdoors on rainy days. The equipment is not waterproof.
- Do not remove the device without permission. Otherwise, electric shock or fire may occur.
- Please find a qualified technician to repair it.

CAUTION

- Do not let children climb on the equipment.
- Keep widgets away from children to prevent them from swallowing.
- If not in use for a long time, please turn off the device and unplug the power plug.
- When adjusting device position, disconnect all power cables and move slowly to avoid tipping.
- It is strictly forbidden to scratch, beat, twist, and/or squeeze with hard objects.
- When the unit is moved from a low temperature to a high temperature, do not start it immediately. Condensation and failure may occur.
- Remove the power plug before cleaning the device. Wipe with a soft cloth; do not use industrial chemicals. Prevent foreign matter from entering the machine. Improper cleaning (such as cleaning fluid or water) can damage the product or erase the printed information. Fluid inflow can cause parts damage, leading to machine failure.
- If the same screen is displayed for a long time, or the moving screen has fixed text or icon(s), it may leave a shadow on the screen, which will not disappear when the machine is powered off. This is normal and not covered by the warranty.
- If the LCD breaks and liquid spills onto your skin, rinse immediately with water for 15 minutes and consult your doctor.
- When carrying the device by hand, hold the unit tightly. Do not put pressure on the panel.
- Use under proper lighting conditions; poor light or prolonged viewing can damage eyesight.
- Please insert the plug correctly into the socket, otherwise it may cause sparks and/or fire.
- Specifications on this contract and packing are subject to change without prior notice. This manual may be slightly different from actual operations.

This Manual is for reference only and is subject to change without prior notice.

If you have any questions regarding our products, please visit us at www.displays2go.com or contact Displays2go customer service at 844-221-3393.

Scan QR code to visit product page.



FEATURES

1. Embedded with Android 7.1 smart operating system and unique UI design, bringing you a more convenient operation and better visual experience.
2. Support USB mouse and keyboard, realizing easy manipulation like a computer. Using a mouse for set up is recommended.
3. Built-in Wi-Fi module, high-capacity memory and high-capacity cache, making it smoother to watch 1080P HD movies and play big games.
4. High-quality LCD screen as the display, with high brightness 3000nits (typ) outward facing screen 1000nits(typ) inward facing screen, readable in direct sunlight in storefront window. Support automatic brightness adjust, Industrial& high temperature resistance LCD, can operation 24/7. No flicker, low radiation, greatly reducing eye fatigue, eye protection, high brightness, high contrast, and wide viewing angle; ultra-fast response time greatly reduces ghosting of fast moving images.
5. Progressive image processing and industry-leading motion compensation technology improve the flickering and blurring in the edges of motion picture.
6. Dynamic contrast technology can significantly improve the clarity and contrast of various screens.
7. Multi-channel USB interfaces, supporting HD media streaming.
8. Slim& light design. Support both free standing and ceiling hanging installation. slim& robust design easily install in store windows, captivates customers with vivid image quality and quiet operation, helps business enhance their brand image while enriching the customers' shopping experience.

IMPORTANT: ASSEMBLY INFORMATION

TWO to THREE people required for lifting, moving, and installation.



Do not put the product in close proximity to a radiator or any other device that produces heat, as this may damage the product.



Some parts of the product consist of glass and other materials that may cause injuries. Handle the product with care.



The product has the capability of producing sound through its speakers and audio output. Do not come in close proximity of the speakers and do not put headphones on high volumes; this may cause hearing damage.



Do not hang on the product or perform any activity in close proximity that may compromise the integrity of the product.



Ventilation slots on the sides and back of the product are important to ensure safety. These slots must never be blocked or covered and the product must never be placed in a restricted place, such as a built-in cabinet or a bookcase. Failing to ensure proper ventilation the product may result in malfunction or overheating, which may result in a fire.

If you have any questions regarding our products, please visit us at www.displays2go.com or contact Displays2go customer service at 844-221-3393.

PARTS LIST



m3x5 Phillips
Screws
(Qty. 16)



m4x6 Phillips
Screws
(Qty. 32)



m6x35
Phillips Screws
(Qty. 8)

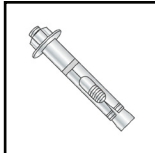

m10x75 Hex
Nut Sleeve
Anchor
(Qty. 3)



Floor Stand Siderail Assembly Parts



Ceiling Mount Siderail & Hanger Assembly Parts

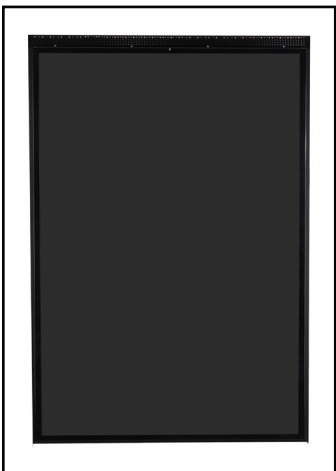

55" Dual Sided Screen



Floor Stand Base



Remote Control

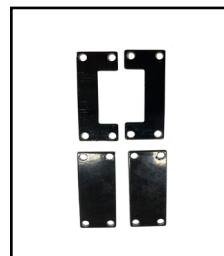

Siderail Cover Plates



Power Cord

Note: LAN Cable is pre-attached and can be found along the side of the screen.

Note: Please disconnect the "Power Cord" before installing or disassembling the unit!

INTERFACES



FLOOR STANDING ASSEMBLY

1. Utilizing the "Floor Stand Siderail Assembly Parts"; assemble two telescopic upper siderails to the lower siderail sections (Fig. 1) with "m4x6 screws" - qty. 4 per side.
2. Attach the two side rail assemblies to the "55" Dual Sided Screen" (Fig. 2 & 3) with "m4x6 screws" - qty. 12 per side.

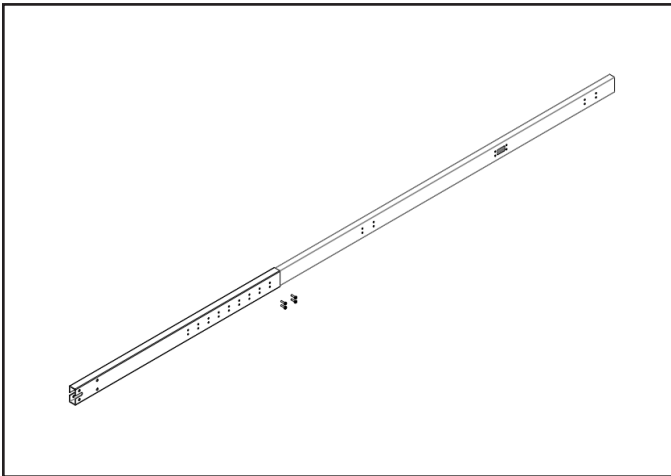

Fig. 1

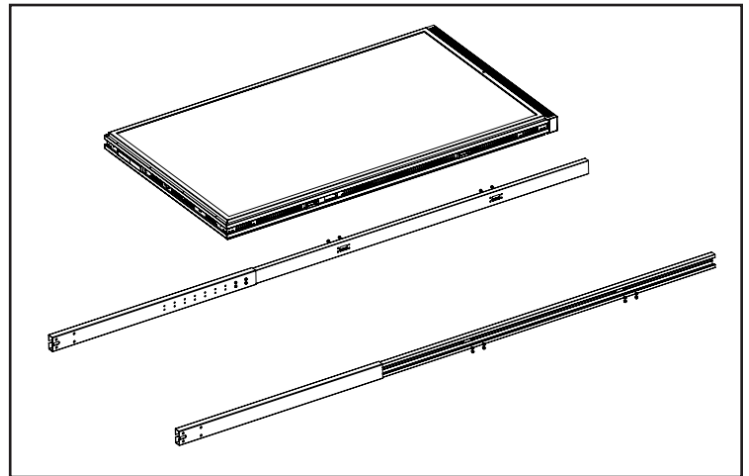

Fig. 2

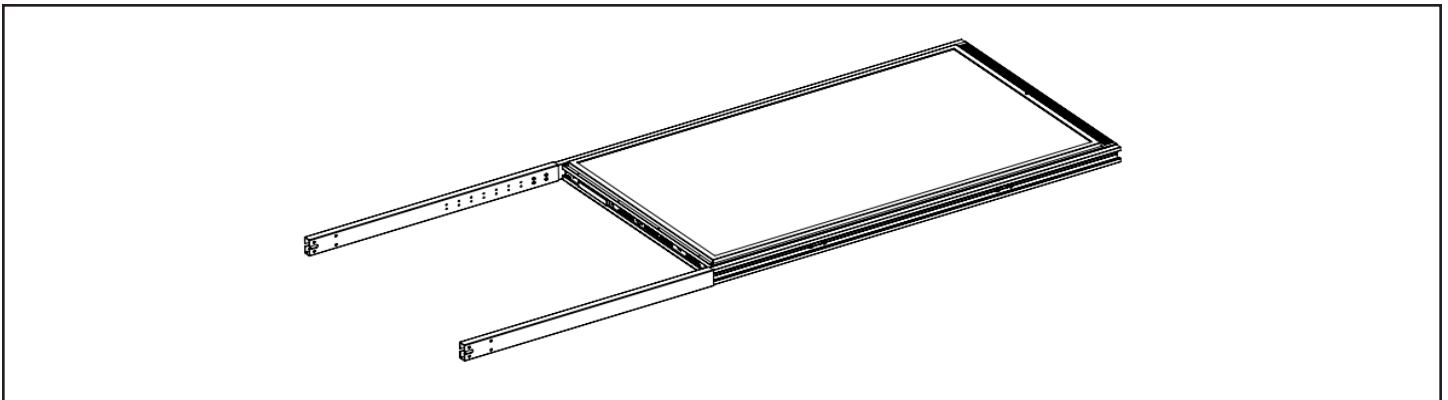

Fig. 3

3. Pull out the internal and external power cords & LAN cable each side in advance and lead them to the bottom of the base along the inside of the telescopic siderails (Fig. 4). Then fix the telescopic siderails to the "Floor Stand Base" with "m6x35 screws" - qty. 4 per side.

Note: Use the pre-attached 3-way spring lever connector block when connecting the internal power cord sections (see inset below).

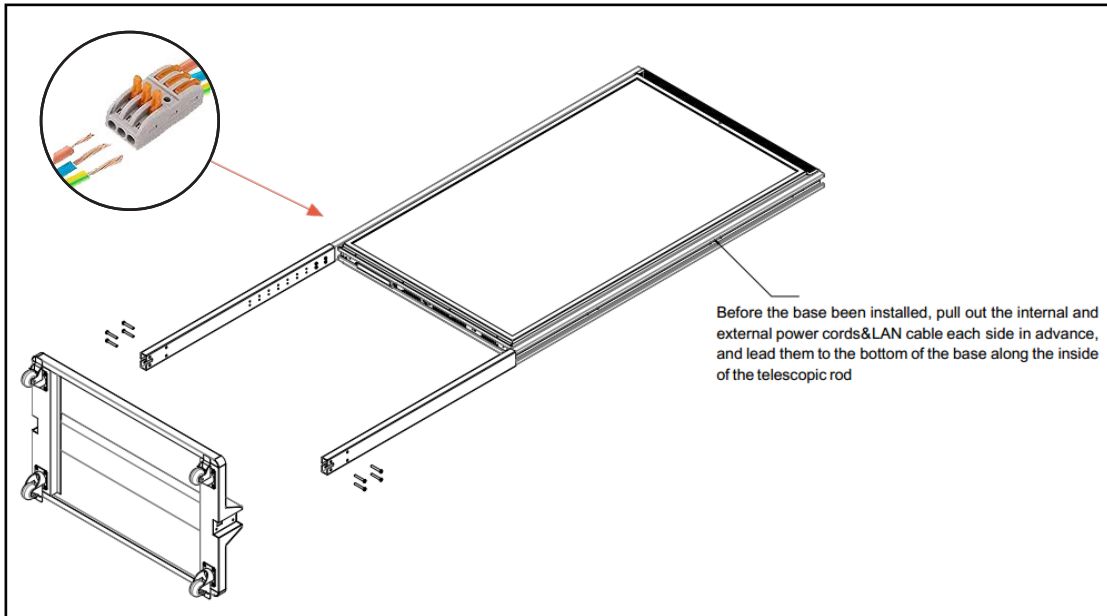

Fig. 4

3. Insert the decorative covers into the telescopic siderails to block the power cord & LAN cable (Fig. 5).

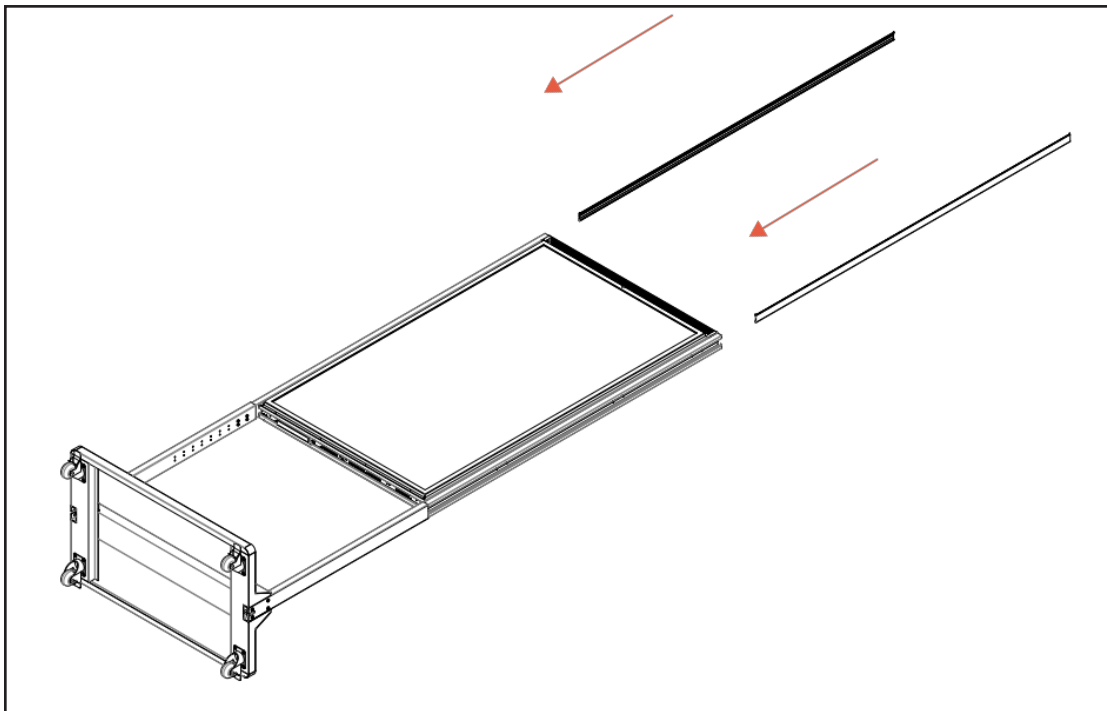

Fig. 5

4. Attach the "Siderail Cover Plates" with "m3x5 screws" - qty. 4 per cover plate (Fig. 6).

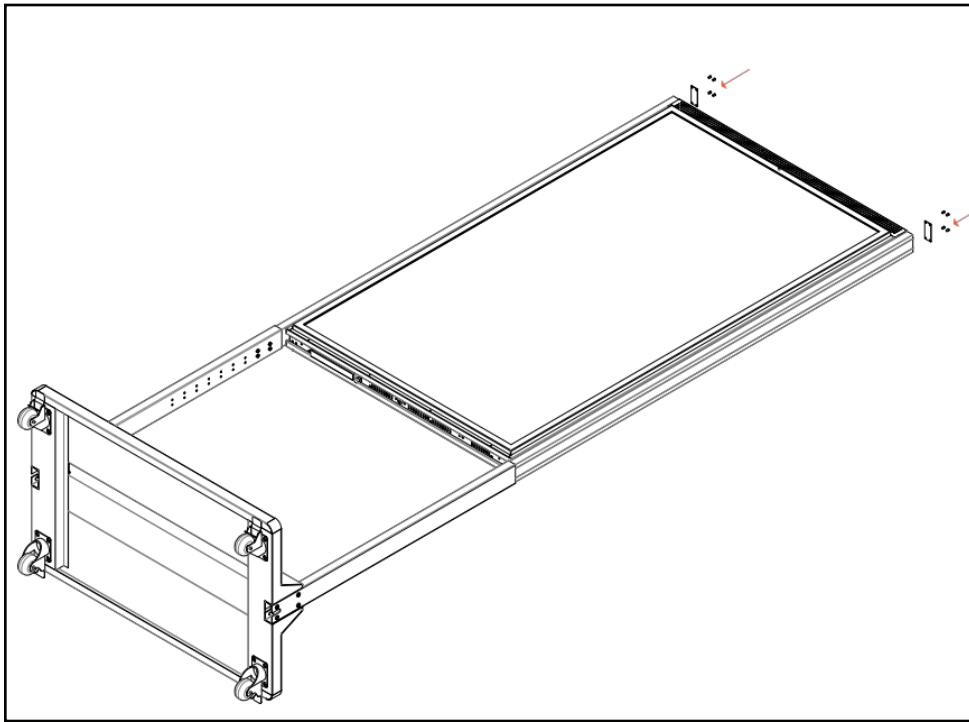

Fig. 6

5. Fully assembled floor standing 55" High Brightness Dual Sided Digital Window Signage (Fig. 7).

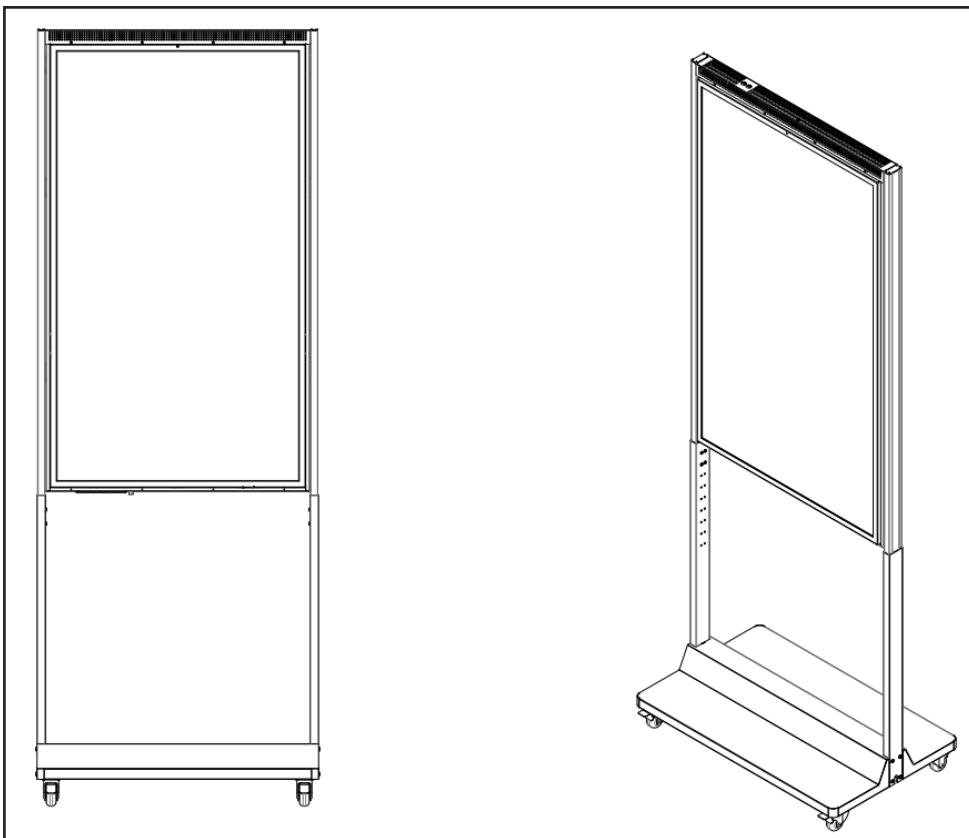

Fig. 7

CEILING MOUNT ASSEMBLY

NOTE: Professional installation is recommended when choosing to install the digital signage by the "Ceiling Mount Assembly".

1. Utilizing the "Ceiling Mount Siderail Assembly Parts"; assemble two telescopic upper siderails to the lower siderail sections (Fig. 1) with "m4x6 screws" - qty. 4 per side.
2. Attach the two side rail assemblies to the "55" Dual Sided Screen" (Fig. 2 & 3) with "m4x6 screws" - qty. 8 per side.

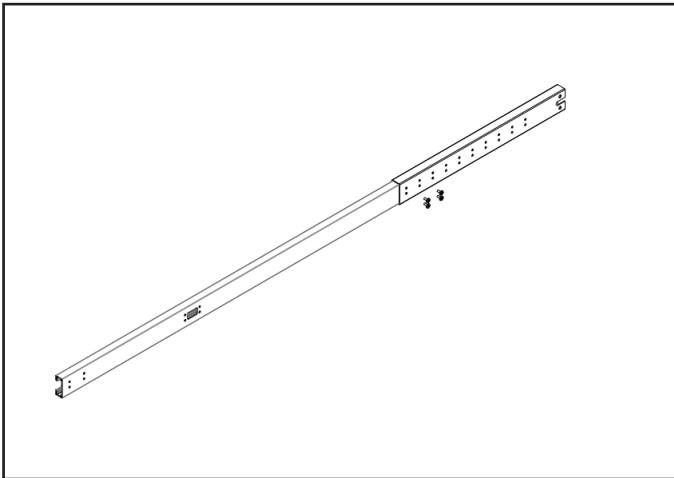

Fig. 1

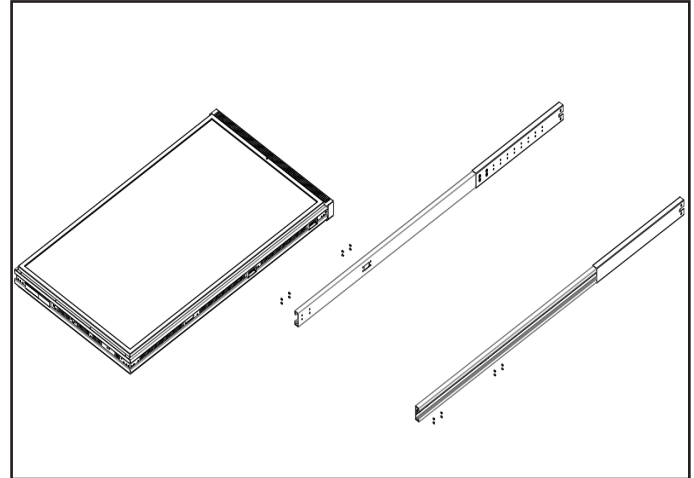

Fig. 2

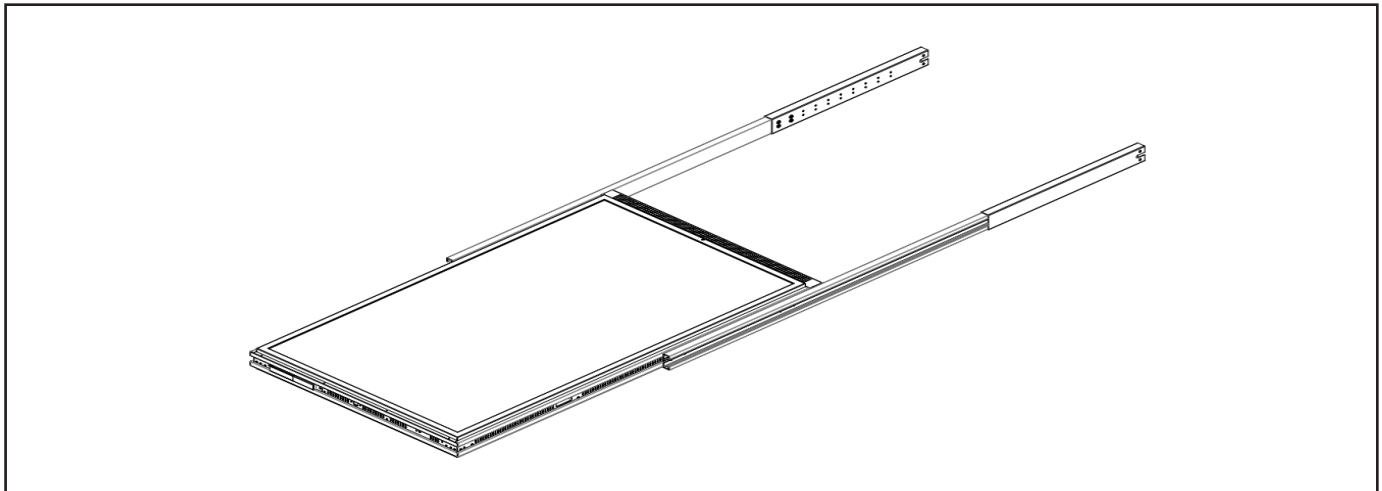

Fig.3

3. Pull out the internal and external power cords & LAN cable each side in advance and lead them to the bottom of the base along the inside of the telescopic siderails (Fig. 4).

Note: Use the pre-attached 3-way spring lever connector block when connecting the internal power cord sections (see inset below).

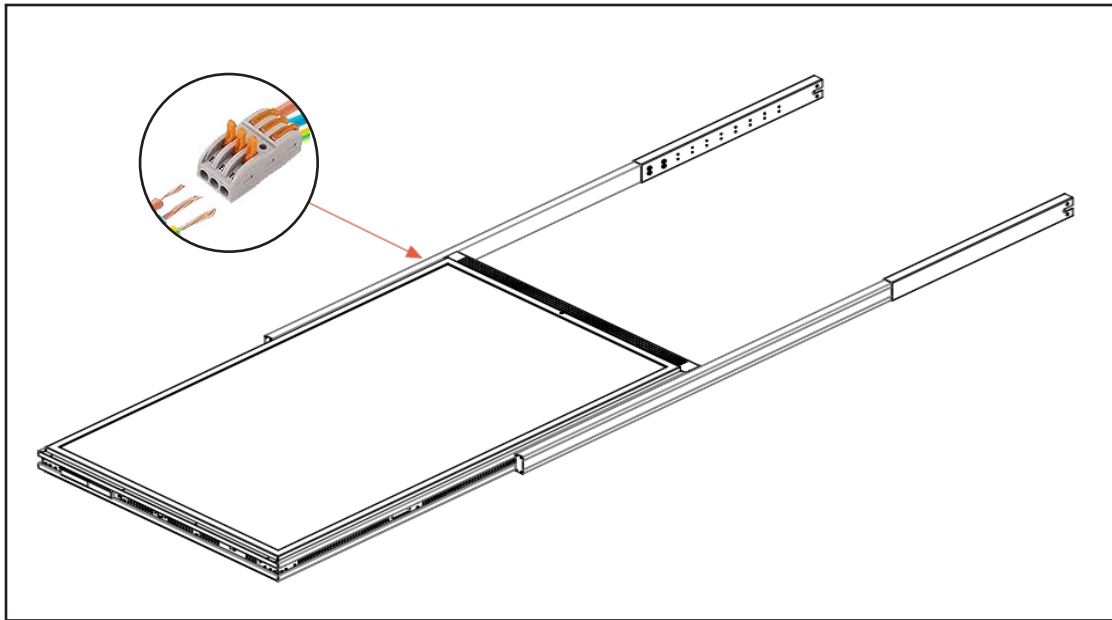

Fig. 4

4. Insert the decorative covers into the telescopic siderails to block the power cord & LAN cable (Fig. 5). Attach the "Siderail Cover Plates" with "m3x5 screws" - qty. 4 per cover plate.

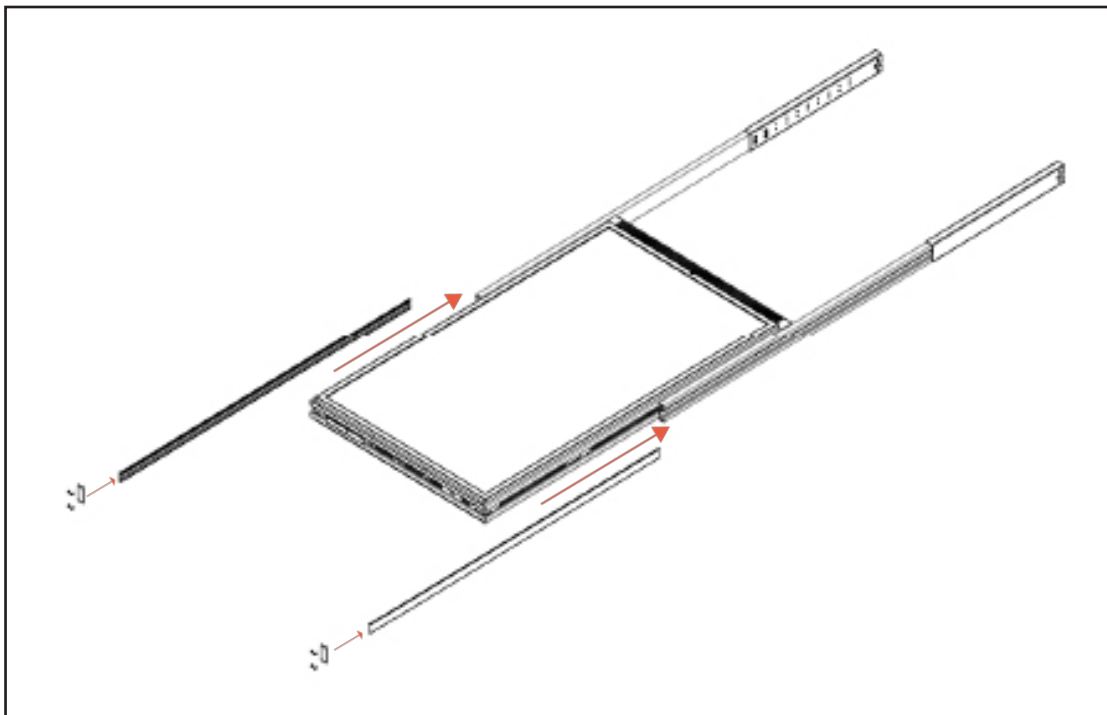

Fig. 5

- Utilizing the "Ceiling Mount Hanger Assembly Parts"; attach the hanger to the ceiling with the supplied "m10x75 Hex Nut Sleeve Anchors" - qty. 3 (Fig. 6).

Note: The "m10x75 Hex Nut Sleeve Anchors" are for use in masonry. Consult your contractor or local hardware store when mounting into drywall or securing to support joists (drop panel ceilings).

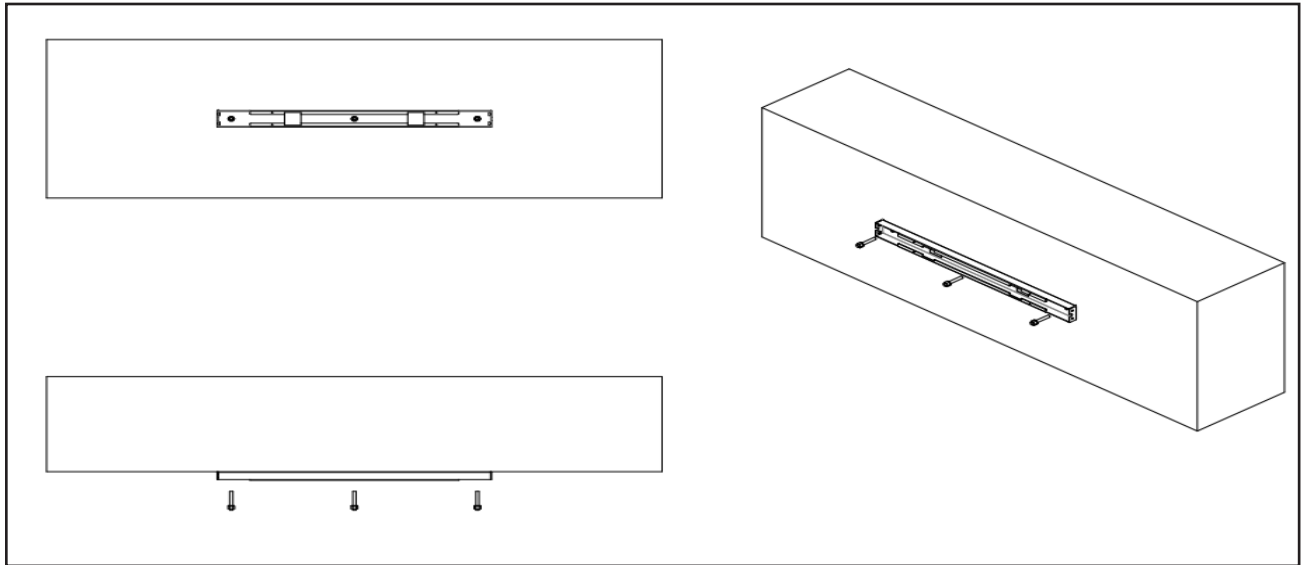

Fig. 6

- Attach the display screen assembly to the "Ceiling Mount Hanger" with "m6x35 screws" - qty. 2 per side (Fig. 7).

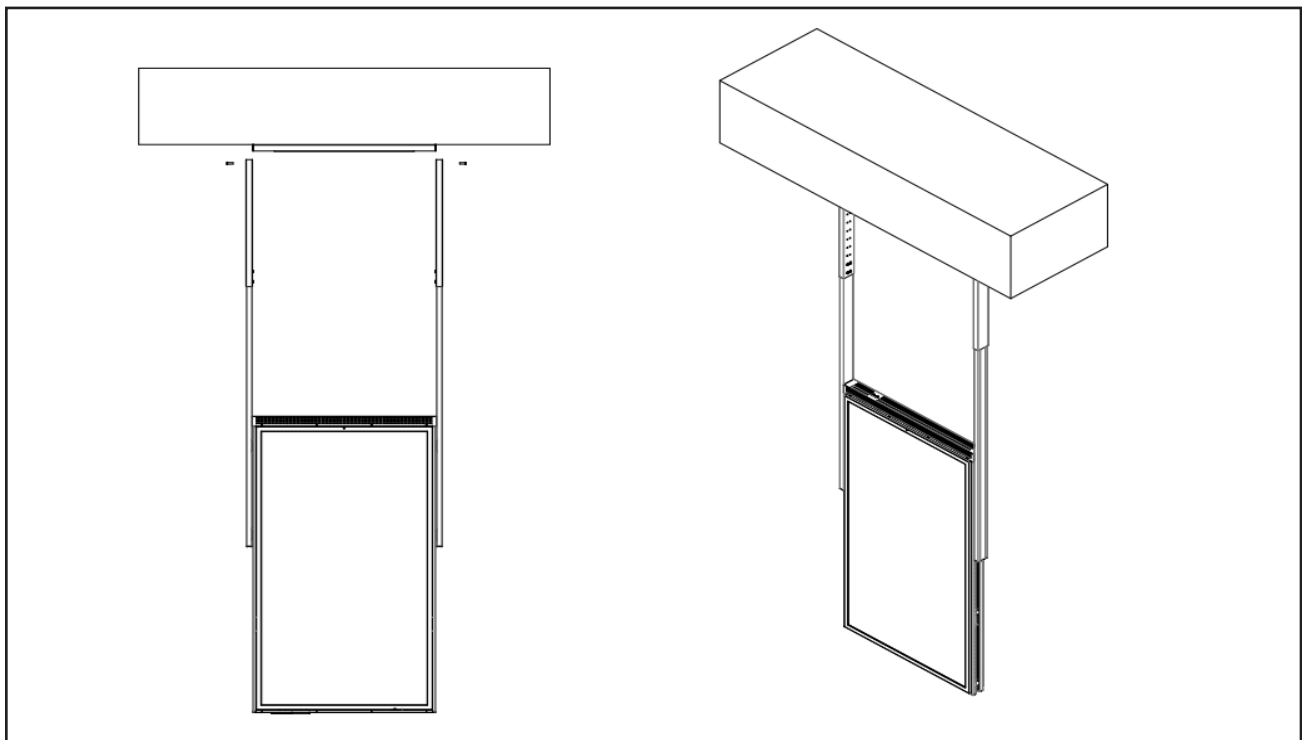

Fig. 7

7. Turn on the external power supply of the displays screen and attach the hanger cover with "m4x6 screws" - qty. 4 (Fig. 8).

Note: Signage can be plugged in or hardwired; consult an electrician for unit to be hardwired.

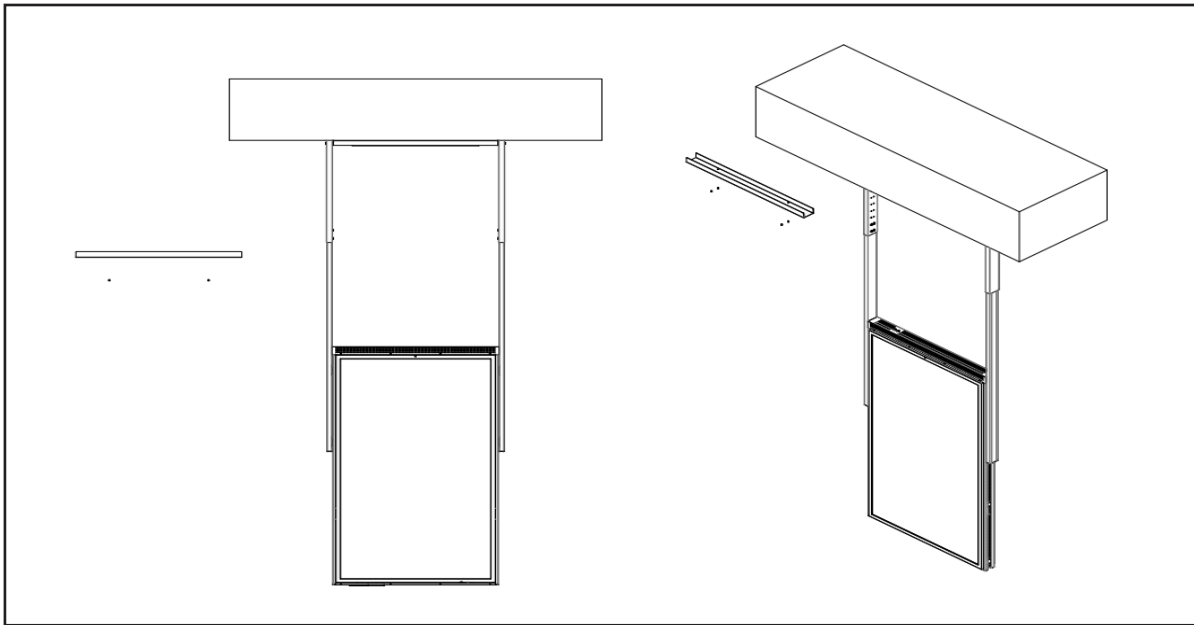

Fig. 8

6. Fully assembled ceiling mounted 55" High Brightness Dual Sided Digital Window Signage (Fig. 9).

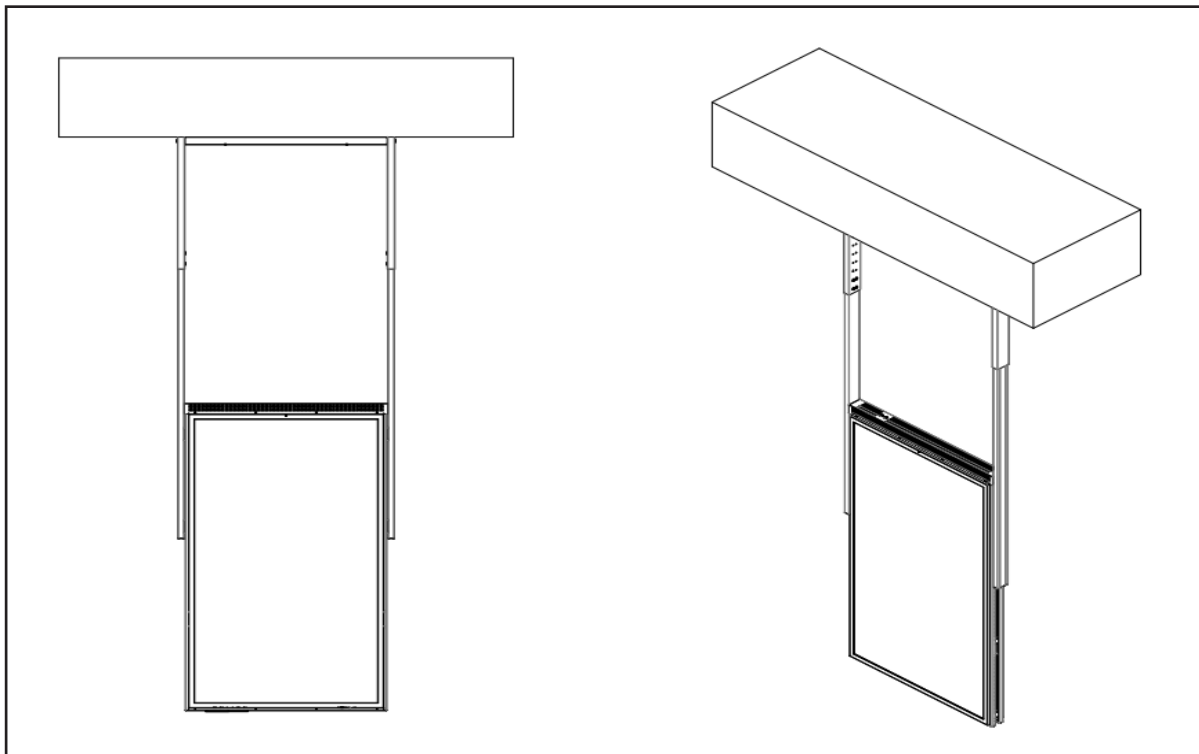

Fig. 9

REMOTE CONTROL

Installing Batteries for the Remote Control

- Aim the remote control at the receiver window. Do not place any object between the remote control and the receiver window to avoid interference with the normal operation.
- Keep the remote control away from violent vibration. In addition, do not set or place the remote control in direct sunlight, or else the remote control may be deformed by heat.
- The remote control may be invalid when the receiver window of the unit is in direct sunlight or strong lighting; in this case, please adjust the angle of the lighting or the unit or approach the receiver window to use it.
- The distance of remote control will be shortened if the battery voltage is insufficient; in this case, please replace with new batteries; if the remote control will not be used for a long time or the batteries are run out, please take out the batteries to avoid corrosion due to battery leakage, which will damage the remote control.
- Do not use batteries of different types or mix new batteries with old ones. Always replace the batteries in pairs.
- Do not put the batteries in fire, or charge or disassemble them, or charge, short circuit, disassemble, heat or burn used batteries. Please dispose of waste batteries in accordance with local environmental regulations. Do not expose the batteries in overheated environments such as sunlight and fire.

Description of remote-control buttons:



Button	Function
	Power switch
	To show the Source menu
	Mute
	Turn up the volume
	Turn down the volume
	Confirm selection
	To move the cursor up
	To move the cursor down
	To move the cursor left
	To move the cursor right
	Remote code lock
	Home button
	Go back to the parent menu
	To show the main menu
	To set up OSD menu

Note: Press the SETUP button in the main interface to call out the OSD menu. After exiting the playback mode by pressing the STOP button, the playback will start according to the schedule next time.

NOTE: The real appearance of the remote control may be different from the picture, please refer to the actual product







BASIC OPERATION OF SYSTEM

Power On/Standby

- Insert the power plug into outlet. If the equipment has a power switch button, switching to “|” will turn it on. Pressing, “O,” will put the equipment in standby state.
- When powered on, enter “System Assistant,” and press the “⏻” button on the remote control, and the equipment enters standby state.

About Launch Desktop

DESKTOP ICONS

	Main Applications
	Back
	Home Page
	Background Applications
	Sound -
	Sound +
	Status Bar Hidden

Switching Wallpaper

We suggest using a mouse/remote control to change the wallpaper. Connect a mouse with the digital panel through USB port, then follow the steps below:

1. Click “Setting.”
2. At the setting menu, click “Display.”
3. At the display setting menu, click “Gallery” or “Wallpaper.”
4. Select an image you would like to set up as background.
5. Confirm the selection by clicking “Set Wallpaper.”

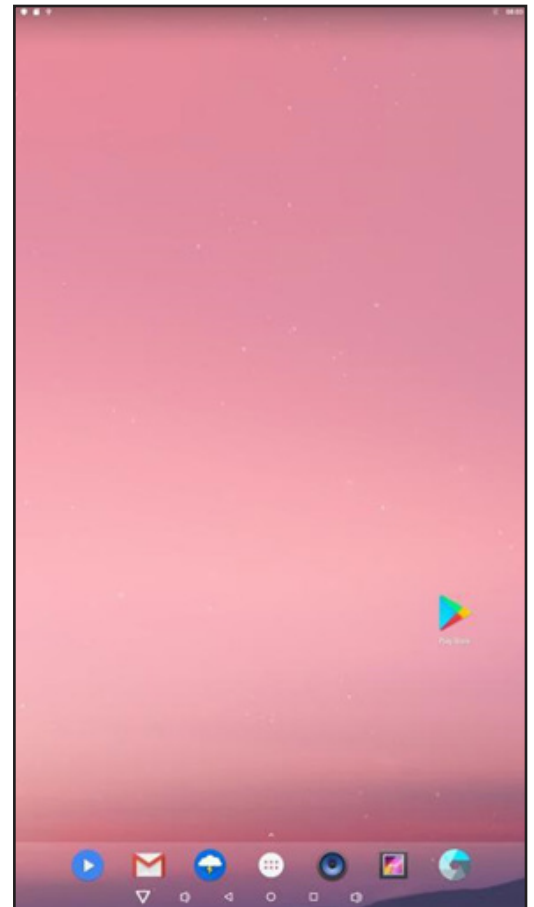

File Management

1. Click the Main Apps button on the home page to enter the Apps menu interface (Fig. 1).
2. Click the "Explorer" icon (Fig. 2) and enter Explorer menu (Fig. 3).
3. Click desired device in the Explorer menu to read the files from each.

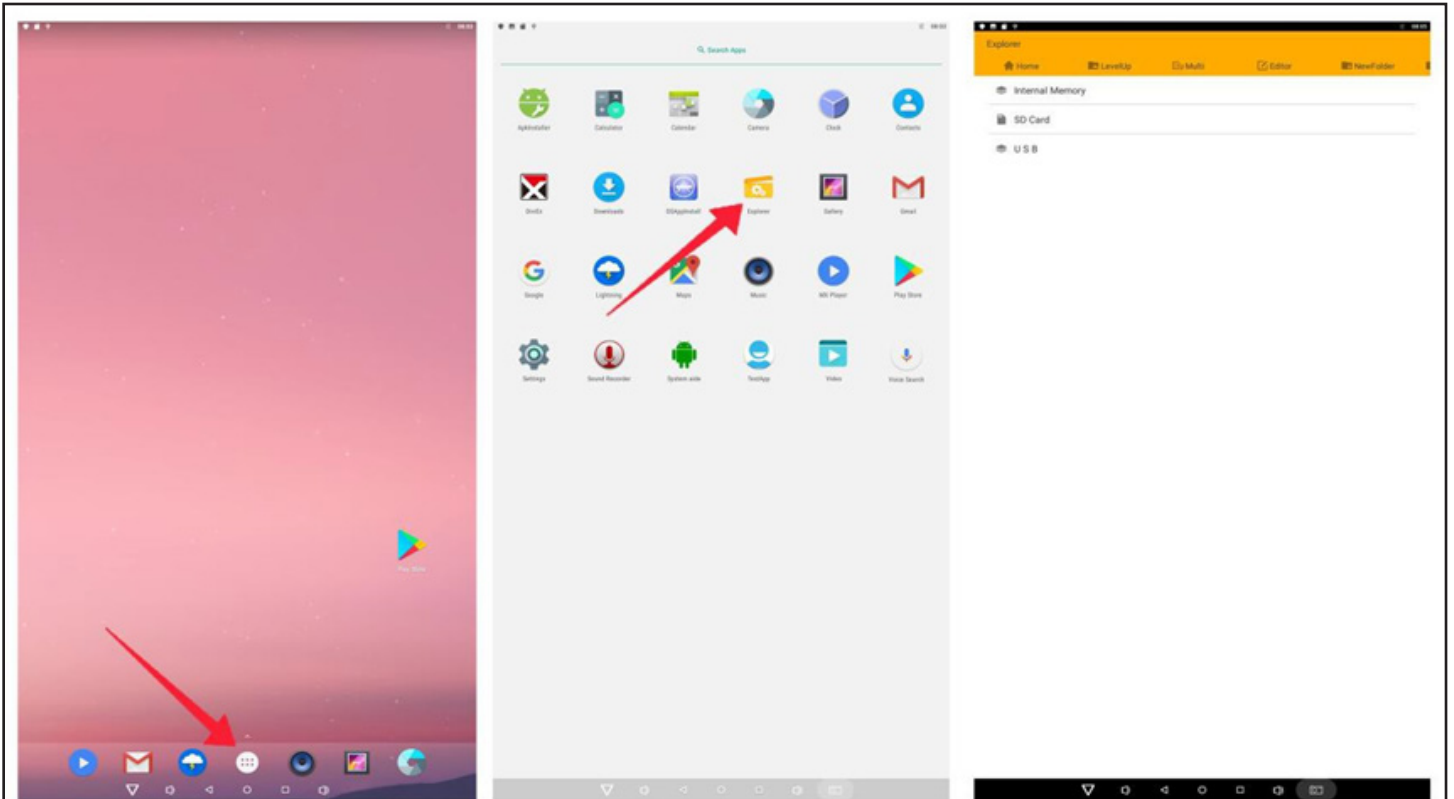

Fig.1

Fig.2

Fig.3

Local Settings

1. Click the Main Apps button on the Home page to enter the apps menu interface (Fig. 4).
2. Click the "Settings" icon (Fig. 5) and enter "Wi-Fi" menu (Fig. 6).
3. Click options in the "Wi-Fi" menu and configure as desired.

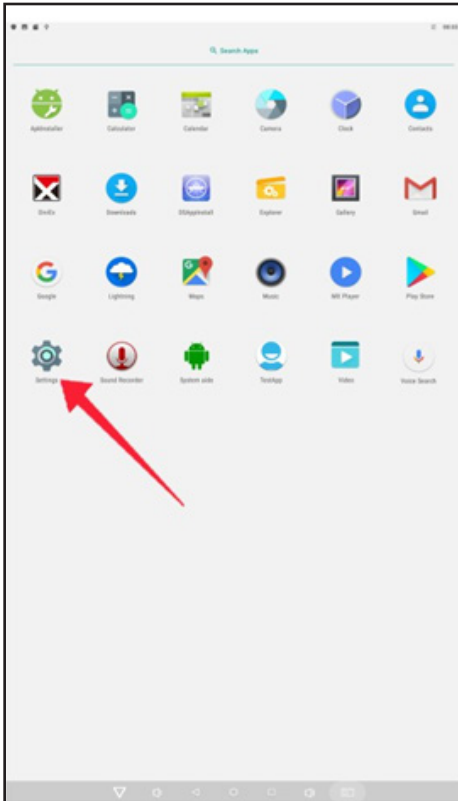

Fig.4

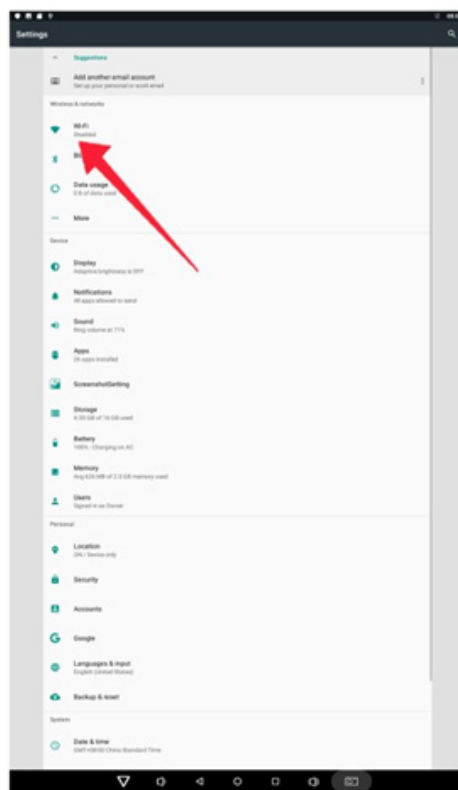

Fig.5

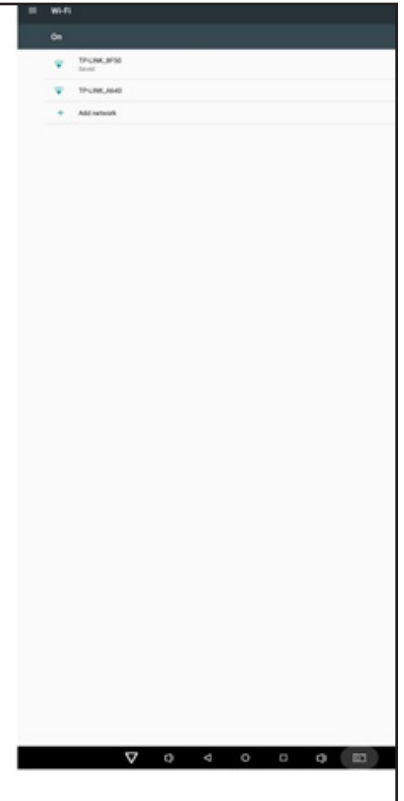

Fig.6

Description of Settings Interface

ICON	DESCRIPTION	ICON	DESCRIPTION
	WiFi Switch		Memory
	Bluetooth		Users
	Data Usage		Location
	Display		Security
	Notifications		Accounts
	Sound		Google
	Apps		Languages & Input
	Screenshot Settings		Backup & Reset
	Storage		Date & Time
	Battery		

NOTE: Click the ▼ icon in the menu to hide the Home Button.

DIVIEX APP INTRODUCTION

How to Upload Media Files

1. Plug in your USB drive to the computer. Open the drive in Windows Explorer (see pg. 11) and create a new folder, rename it "MediaFolder".

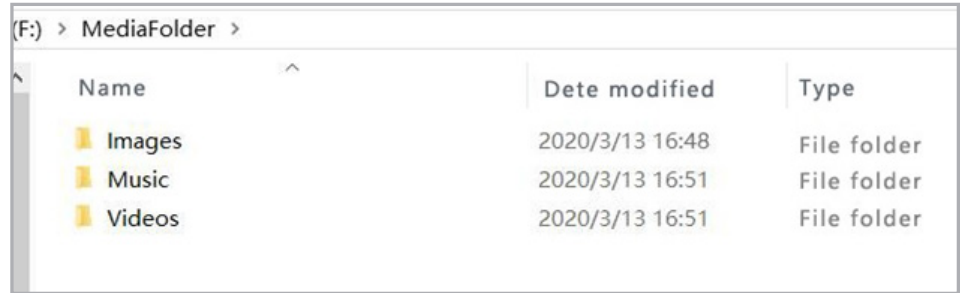

2. Open "MediaFolder," create 3 subfolders, and change their names to "Images," "Videos," "Music."
3. Copy the media files to be displayed in the slideshow and paste to the appropriate new folder: "Images" or "Videos."
4. Copy and paste music files to "Music" folder.

SUPPORTED MEDIA FORMATS:

Image	JPG/JPEG/BMP/PNG
Video	MPEG1/MPEG2/MPEG4/H.264/H.265/WMV/MKV/TS/flv
Music	AAC/MP3/AMR/OGG/PCM

Usb Disk: Copy finished

5. Plug the USB drive into the device and click the DiViEx app.

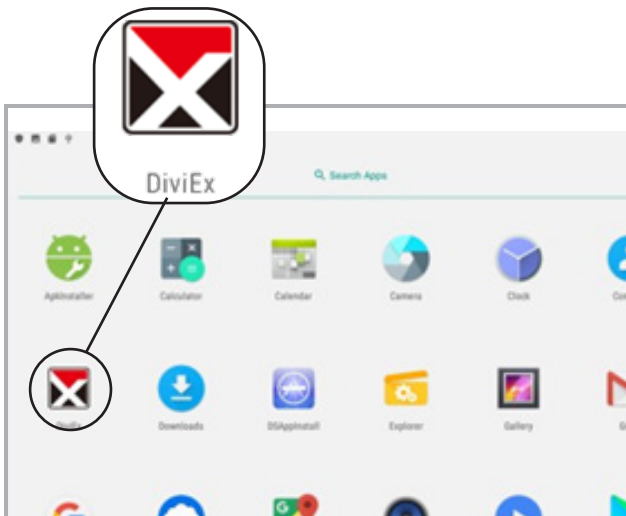

6. When the screen shows "Copy finished" after "USB Disk," the media files are ready to be displayed.

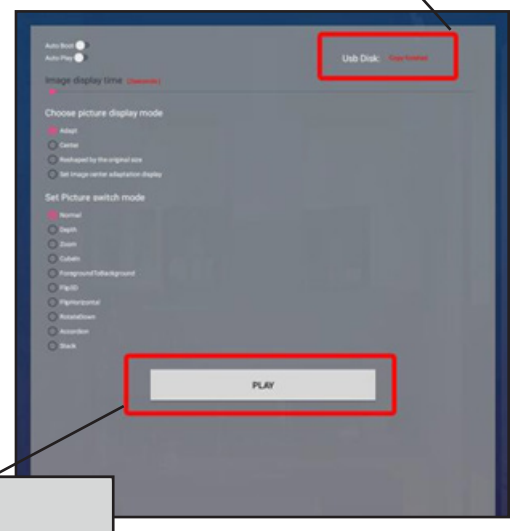

Edit Picture

This function shows all pictures, all pictures can be edited or removed, as desired.

Crop

There are four corner handles and four border handles to crop the picture. Click and drag a handle to reshape the image to desired size.

Filter

A variety of different filters are available in the filter gallery below the image. The app supports the following filters:

Auto-Fix	Due Tone	Grayscale	Sepia
Black & White	Fill Light	Lomish	Sharpen
Brightness	Fish Eye	Negative	Temperature
Contrast	Flip (Horizontal, Vertical)	Posterize	Tint
Cross-Process	Grain	Rotate	Vignette
Documentary		Saturate	

Reset

Click "Reset" to remove all the editing you applied to the image.

Save 

Click the icon to save the edited image as a new image.

Delete Photo

Click "X" to delete unwanted pictures.

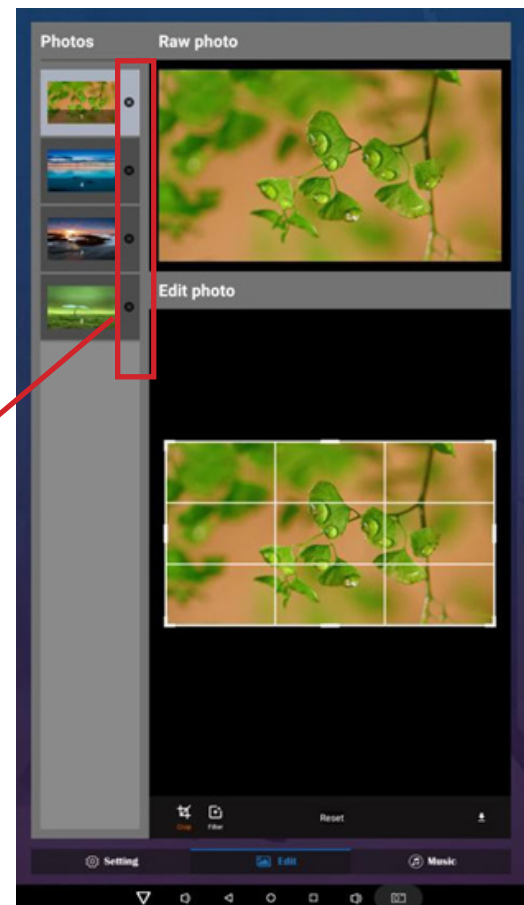
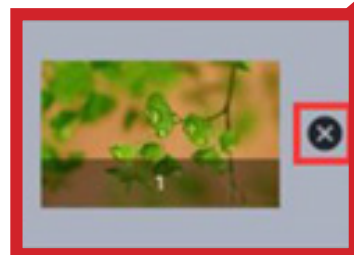

Music

This function allows you to add music files to play in the background of your display. In order to do this, you must add all desired music files in the playlist library.

1. Add desired background music to "Playing List Music" from the playlist library. To do this, click the right arrow on the desired music file. This will add the track to the "Playing List Music" column.
2. To remove music from the background music playlist, use the left arrow on the track you wish to remove.

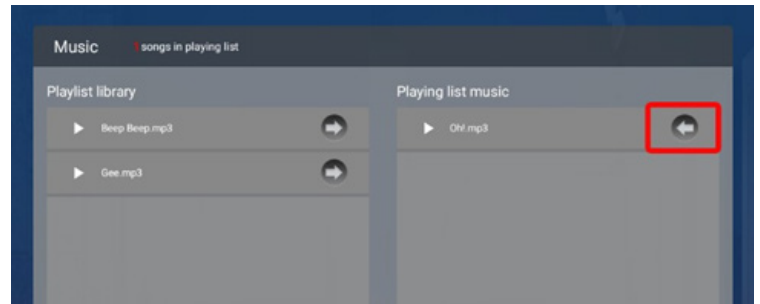
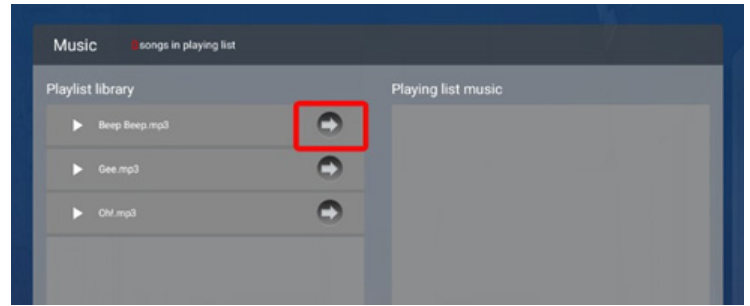

Factory Reset

1. Go to Settings, then click "Backup & Reset."
2. Click "Factory Data Reset."
3. Choose "Erase SD Card," then click "RESET DEVICE" to restore unit to default settings.

Screen Rotation

1. On home page, click Main Apps button to enter the app menu interface.
2. Click "System Aide."
3. Click "Rotate Screen." (Fig.1)
4. Choose the degree to which you'd like to rotate screen, then click "Confirm." Upon **restarting** the unit, the screen will be rotated. (Fig.3)

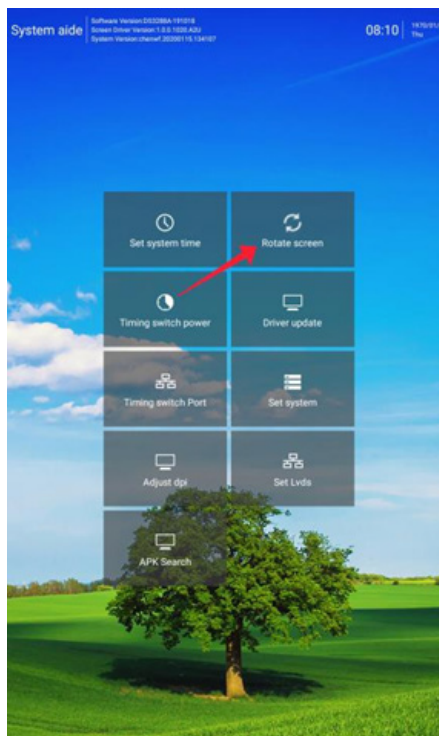

Fig.2

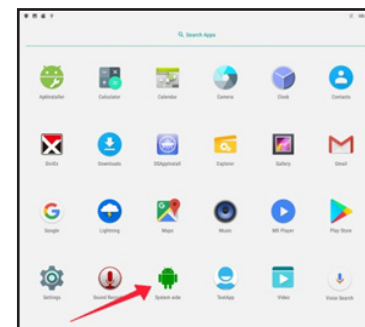

Fig.1

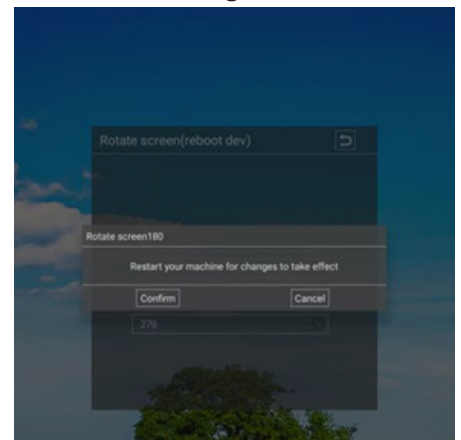

Fig.3

System Language

1. Navigate into Settings, then click "Language & Input."
2. Click "Languages," then click "Add a Language."
3. You can add the required system language from the existing list of languages. Scroll to find the desired language, then select to add to system.
4. Then, drag desired system language to the top of the list to make it the system default.(Fig. 1)

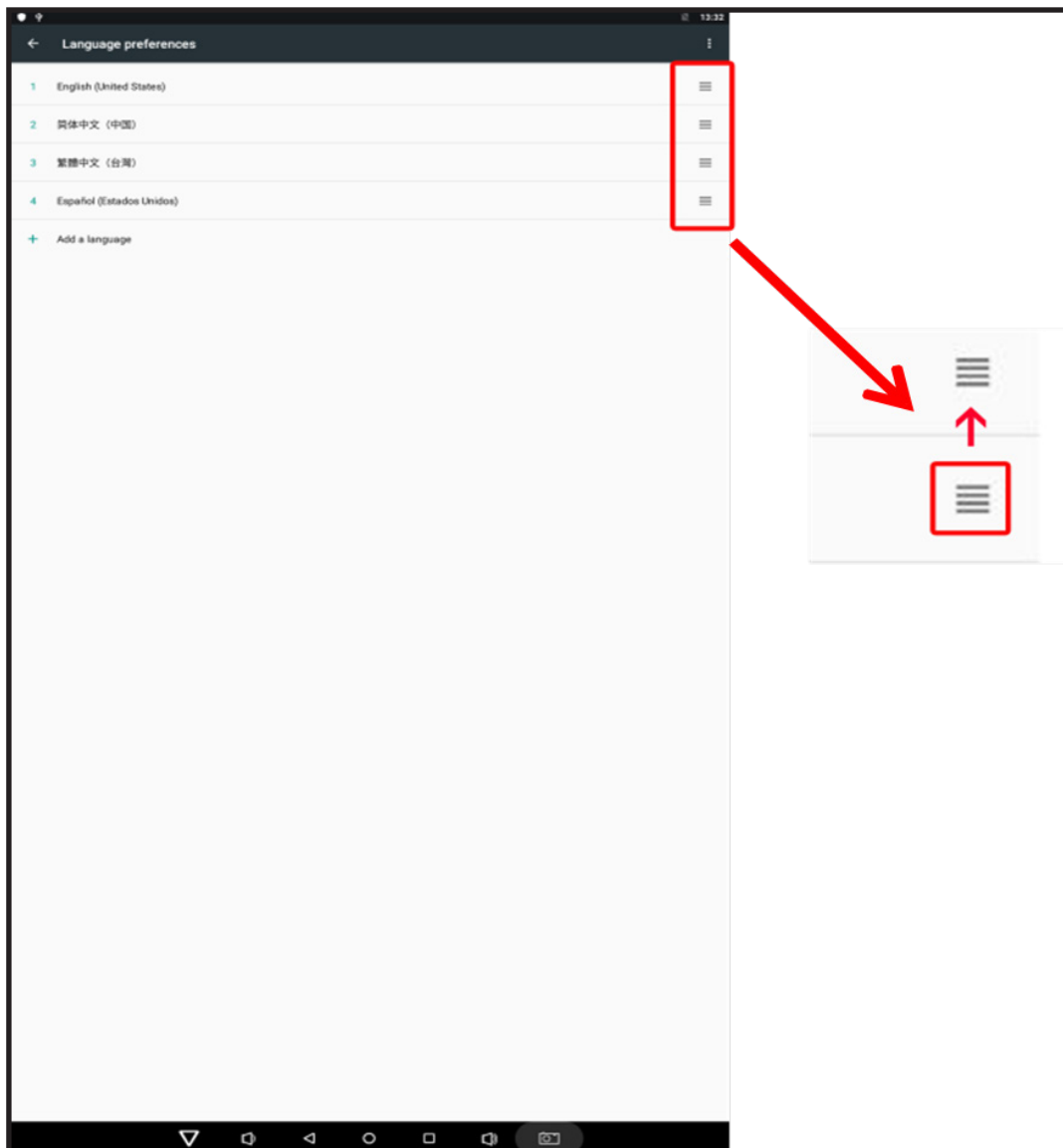

Fig.1

Technical Specifications

	Item	Specification
Panel	LCD Size	55"
	Resolution	1980 * 1080 (pixels)
	Brightness (typ.)/(min.)	3000 nits outward facing screen / 1000 nits inward facing screen
	Contrast (typ.)	1100:1 (typ.)
	Response (ms)	10ms (typ.)
	Pixel Pitch	0.21 (H) mm * 0.63 (V) mm
	Refresh Rate	60Hz
	Viewing Angle	178° (H)/178° (V)
	Viewable Area	1214.2 (H) mm * 685 (V) mm
	Chromaticness	16.7M
Power Supply	Voltage	100V~240V, 50-60Hz
	Power Consumption	≤280W
Environment	Operating Temperature (°C)	0~40°C
	Storage Temperature (°C)	-10~60°C
	Storage Humidity	10~60% RH Non-condensing
	Operating Humidity	20~80% RH Non-condensing
	Operating System	Android 7.1
Functions	Processor	RK3288, quad-core
	RAM	2G
	Built-In Memory	16G
	Decoding Resolution	1080P UHD compatible
	Playback Mode	Support loop, inter-cut, timer, shim, etc.
	Touch Support	N/A
	Supported Video Files	AVI, MPEG4, WMV, MKV, FLV, MP4, MOV
	Supported Photo Files	JPG, JPEG, BMP, PNG, GIF
	Audio Output, Supported Files	Left and right audio channel, MP3
	RTC (Real-Time Clock)	Yes
	Schedule Power On/Off	Yes
	System Update	USB compatible
App Installment	Support download and installation	

I/O Interfaces	TF	N/A
	Ethernet (RJ45)	1
	HDMI	N/A
	VGA	N/A
I/O Interfaces (cont'd)	Headset	N/A
	USB	2
	SIM	N/A
Structure	Net Weight	48kg
	Gross Weight	65kg
	Unit Dimensions (WxDxH)	1920~2160*788.3*500mm (Standing) 2330~2650*792.6*74mm (hanging)
	Package Dimensions (WxDxH)	≈1410*250*910mm (Frame) 800*245*510mm(Base)
	Shell Material	Aluminum profile/sheet metal
	Shell Color	Black
Language	OSD	English/Simplified Chinese

Cleaning and Maintenance

1. Avoid strong vibration or impact on the product.
2. Keep the product dry to avoid possible damage by moisture.
3. Do not place the product under direct sunlight, which may shorten the service life of the screen.
4. Clean screen and product using a glass cleaner.
5. If the product will not be in use for a long time, pull out the power cord to prevent the internal short circuiting or other potential dangers.

Recycling and Disposal Regulations

To protect the earth, if you do not need this product or its service life expires, please abide by your local Waste Electrical and Electronic Products Recycling and Disposal Regulations or send it to a qualified local manufacturer for recycling.

Troubleshooting Guide

Issue	Probable Cause	Solutions
No Picture or Sound	<ul style="list-style-type: none"> -Unit is not plugged into the wall. -Power cord not properly connected to the terminal on the back of the unit. -Unit is not powered on. -Wall outlet is not working. 	<ul style="list-style-type: none"> -Check that unit is plugged into wall. -Confirm that the power cord is connected to the terminal on the back of the unit. -Turn the on/off toggle switch to the "on" position. -Unplug unit, wait 20 seconds, plug unit back into outlet and try again. -Make sure that outlet is working by plugging in a different electrical device.
No Sound (Picture Is Working)	<ul style="list-style-type: none"> -Volume has not been adjusted on the remote control. -Content/Video does not have sound. -Content format is not compatible. -Speakers do not work. 	<ul style="list-style-type: none"> -Adjust volume using the remote control. -Confirm content is one of the following compatible formats: AVI, MPEG4, WMV, MKV, flv, MP3, MP4, MOV. -If unit is connected to Wi-Fi, go to YouTube and play video that has sound as a test. -Unplug unit, wait 20 seconds, plug unit back into outlet and try again. -Try playing the content on a different device (smart phone, computer, or tablet).
No Picture (Sound Is Working)	<ul style="list-style-type: none"> -Content file is damaged. -Content format is not compatible. -Screen is damaged or defective. 	<ul style="list-style-type: none"> -Confirm content is one of the following compatible formats: AVI, MPEG4, WMV, MKV, flv, MP3, MP4, MOV. -Try playing the content on a different device (smart phone, computer, or tablet). -Unplug unit, wait 20 seconds, plug unit back into outlet and try again.
Remote Control Not Working	<ul style="list-style-type: none"> -Batteries were not inserted properly. -Batteries are dead. -Standing too close or too far from the unit. 	<ul style="list-style-type: none"> -Check that battery is inserted properly with positive and negative orientation. -Insert new batteries. -Stand within 1 foot of the front of the unit and point the remote directly at the sensor (green dot).
No Wi-Fi Signal	<ul style="list-style-type: none"> -Wi-Fi is not turned on in product settings. -Wi-Fi is not connected to a network. -Low or no signal from the router. -Antenna is missing or not pointed upward. -Damaged PC board. 	<ul style="list-style-type: none"> -Check that Wi-Fi is turned on in settings: Click the settings icon from the Android home screen.  Click "Wi-Fi." Click the on/off icon in the upper right hand corner to turn on Wi-Fi. "On" will appear on the upper left side. Select your Wi-Fi network.  -Confirm that the antenna is in place and pointed upward. -Check that other devices are receiving the signal. If other devices are not receiving the Wi-Fi signal, please contact your internet service provider. -Unplug or reset the router and wait for 20 seconds. Restart the router and check.

Parts Missing or Damaged	-Parts missed during manufacturing. (No charge for replacements.) -Parts lost or damaged by the customer. (There is charge for replacements.)	Contact a customer service representative.
Cannot Upload Content	-Content format is not compatible. -Content files are too large. -Port being used is defective. -App being used to play content is defective. -Android board is defective.	-Confirm content is one of the following compatible formats: AVI, MPEG4, WMV, MKV, flv, MP3, MP4, MOV. -Confirm file size is less than available space.
Issues Using Pre-Installed Apps	-Mistake in storing content to NAND Flash. -App is defective. -Android board is defective.	-SlideShow App steps: <i>Explorer > Select USB > Select Multi > highlight files > Editor > Select Copy > Home > NAND > MediaFolder > Images> Editor > Paste</i> <i>Open SlideShow app and select desired transitions, slide time and looping > Play</i> -MX Player steps: <i>> Follow same steps as SlideShow App > MediaFolder > Video > Editor > Paste.</i> o Open MX Player and select video to play. o Loop video: While the video is playing, click on the video and there should be 3 dots in the top right corner. Click on the 3 dots > play > check desired Loop option.



If all of the potential solutions have been tested for a particular issue and problems have not been resolved, contact a customer service representative for guidance.

Contact Information:

Website: www.displays2go.com

Phone: **844-221-3393**